

TOWNSHIP OF ARCADIA
DRIVEWAY ORDINANCE
ORDINANCE NO. 405

An Ordinance to establish minimum driveway standards in order to improve response time and insure adequate access by emergency services vehicles; to provide for inspections; to repeal the former Ordinance; and to provide for civil infraction penalties.

TOWNSHIP OF ARCADIA ORDAINS:

Section 1. STANDARDS. The following standards shall apply to all private driveways, other than field entrances used solely for farm equipment, within Arcadia Township:

- A. All trees and brush shall be kept cleared for a minimum width of fourteen (14) feet for the full length of all private drives.
- B. All topsoil, stumps, and unstable soil shall be removed from a minimum twelve (12) feet driveway width and the area shall be backfilled with appropriate granular material. The driveway shall be surfaced with gravel, crushed limestone, finely crushed concrete or similar material for the minimum width of twelve (12) feet for the full length of the driveway.
- C. The surface of the driveway shall be properly drained so that water damage and frost heave will not impede access by emergency vehicles.
- D. Driveways shall provide a minimum centerline radius of forty (40) feet for all curves to insure access by fire fighting equipment. (Refer to Figure 1 for an illustration of this standard.) In addition, the driveway shall provide minimum clearance from trees and bushes of eighteen (18) feet through all curved sections.
- E. No bridges shall be permitted as part of driveway construction unless they are certified by a registered Civil Engineer as capable of supporting a 30 ton fire truck.
- F. No structures shall be placed over or across any driveway unless they maintain not less than fourteen (14) vertical and horizontal clearance.
- G. In case of driveways which extend over one hundred (100) feet from the center of the road to the nearest part on the principal structure, a staging area shall be provided. The staging area shall be at least fifty (50) feet by fifty (50) feet square and shall be properly drained. The staging area shall be located between fifty (50) feet and one hundred (100) feet from the principal structure and shall be accessible from the driveway. The staging area may include part of the driveway.
- H. No driveway may enter a road right-of-way at less than a sixty (60) degree angle.

Section 2. INSPECTIONS AND FEES. All driveways shall be inspected and approved by a designated Township agent prior to a certificate of occupancy being granted for any residential structure to be served by the driveway. Any fees or bonds applicable to a driveway approval shall be the responsibility of the property owner.

Section 3. REPEAL. The former Arcadia Township Driveway Ordinance 403, adopted on November 9, 1994, is hereby repealed.

Section 4. PENALTY. Any person, firm, or corporation who violates any of the provisions of this Ordinance is responsible for a municipal civil infraction, subject to payment of a civil fine of not less than Fifty (\$50.00) Dollars, plus costs and other sanctions, for each infraction. Repeat offenses under this Ordinance shall be subject to increased fines as provided for in the Civil Infraction Ordinance, Ordinance No. 2100.

The undersigned Supervisor and Clerk of the Township of Arcadia hereby certify that this Ordinance was duly adopted by the Arcadia Township Board at a meeting held on the 8th day of June, 1999 and as published in The County Press on the 16th day of June, 1999. Said Ordinance shall become effective thirty (30) days after said date of publication.

Center Radius = 40'

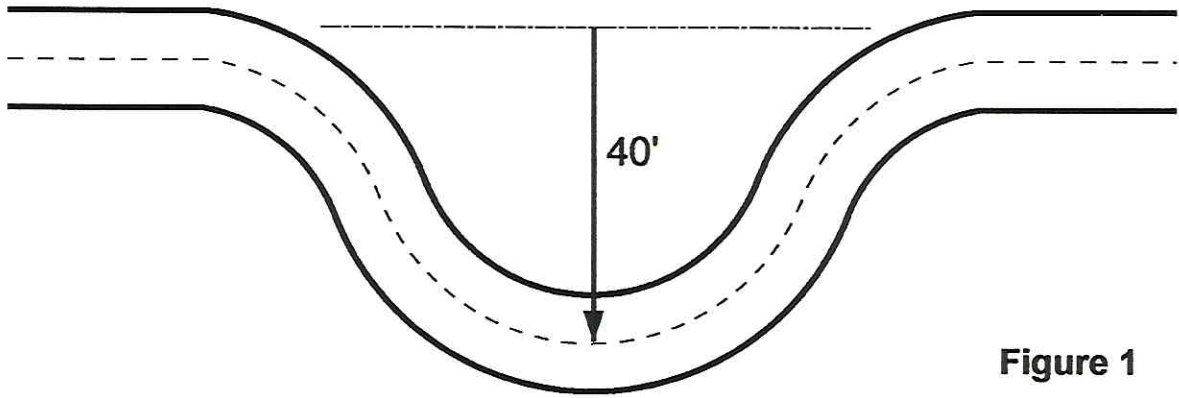

Figure 1

HOUSE

GARAGE

50 to 100 feet
from House or
Garage

**Staging Area
50 x 50 Feet
Clear of all obstructions**

Figure 2

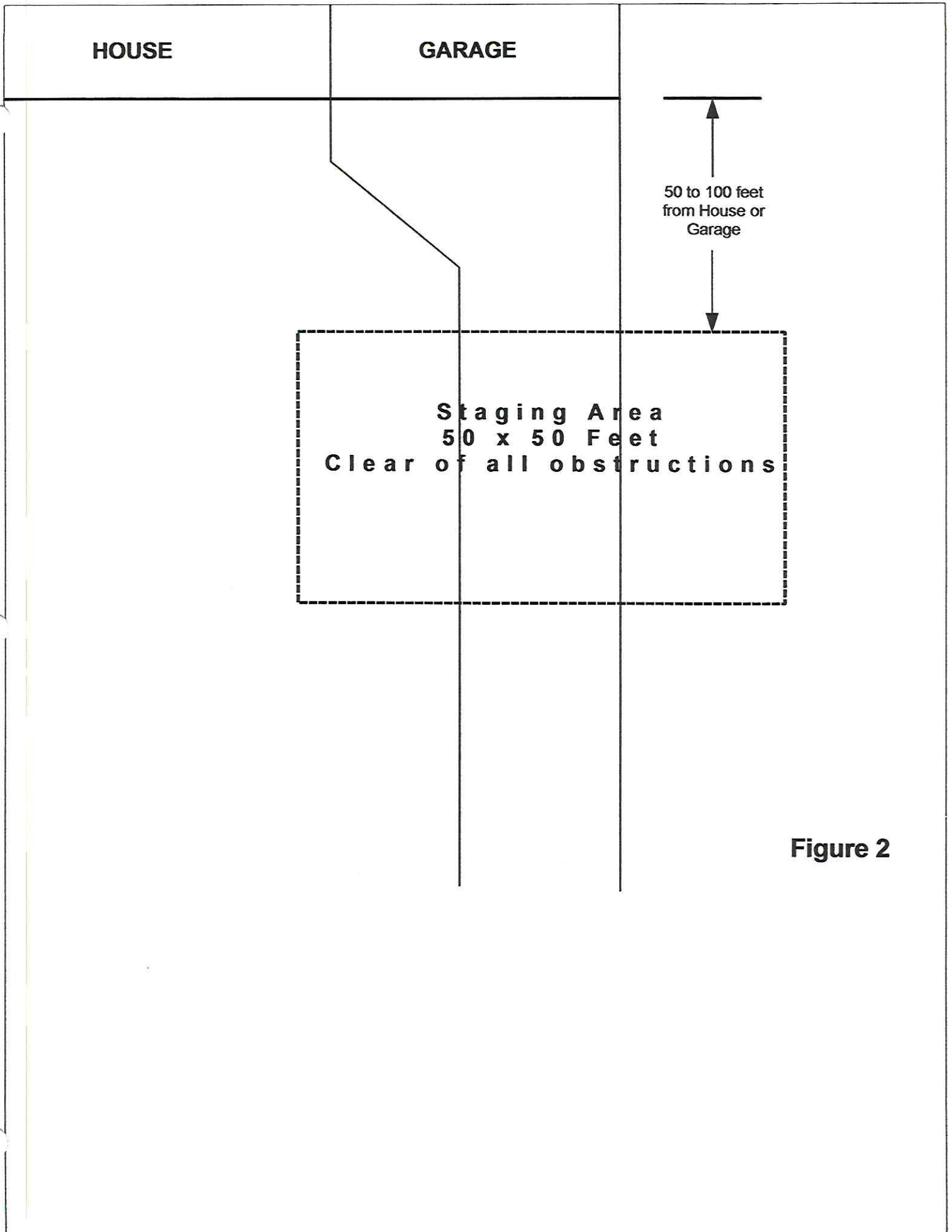

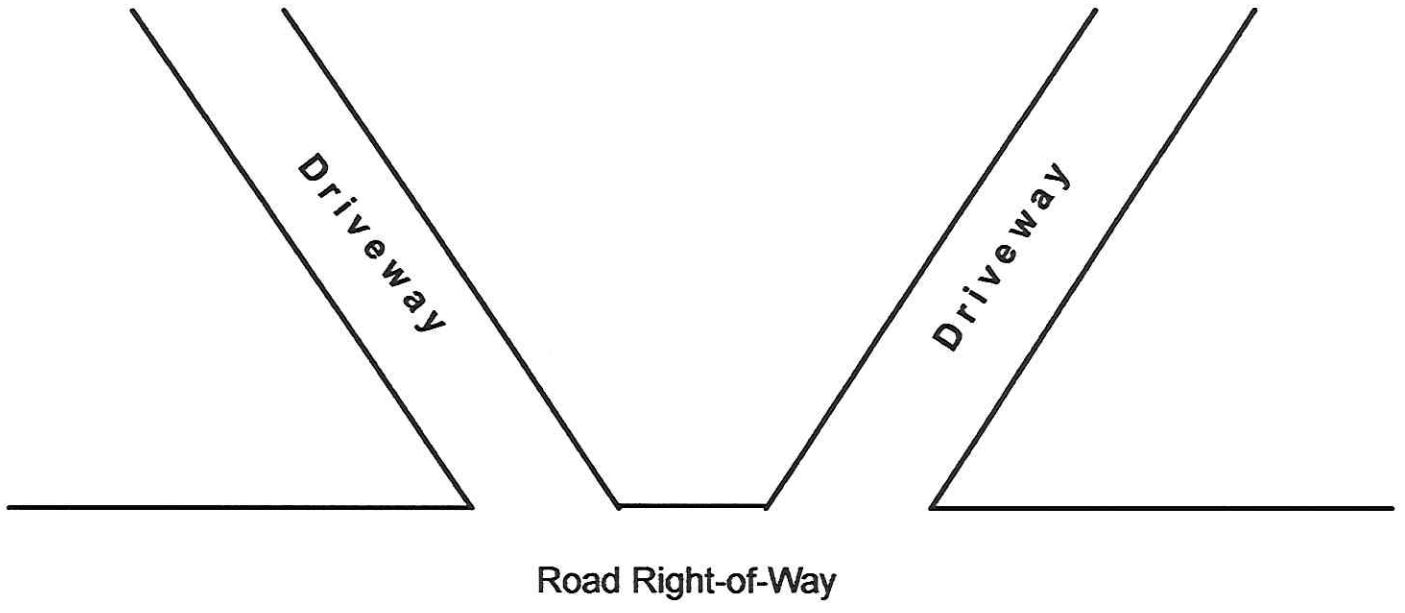

NO LESS THAN 60 DEGREE ANGLE

Figure 3